



5/8" BORE ACCESSORIES



CB-0895

Clevis Bracket
Material: Steel, bright zinc plated

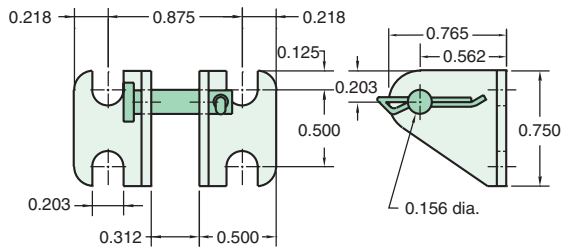

RC-0881

Rod Clevis
Material: Steel, electroless nickel plate

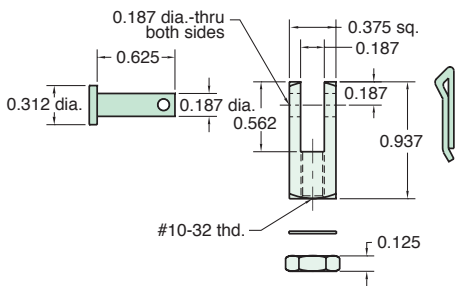

FB-0891

Foot Bracket
Material: Steel, bright zinc plated

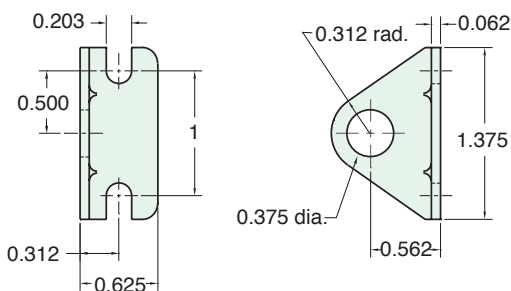

MOUNTING NUTS

Stud Nut

Part Number	Across Flats	Nut Thickness	Nut (Thread)
N06-24A	9/16"	7/32"	3/8-24
N06-24B	1/2"	1/8"	3/8-24
N07-20	11/16"	1/4"	7/16-20

Rod Nut

Part Number	Across Flats	Nut Thickness	Nut (Thread)
N03-32	3/8"	1/8"	#10-32

RE-0885

Rod End
Material: Steel, bright zinc plated body

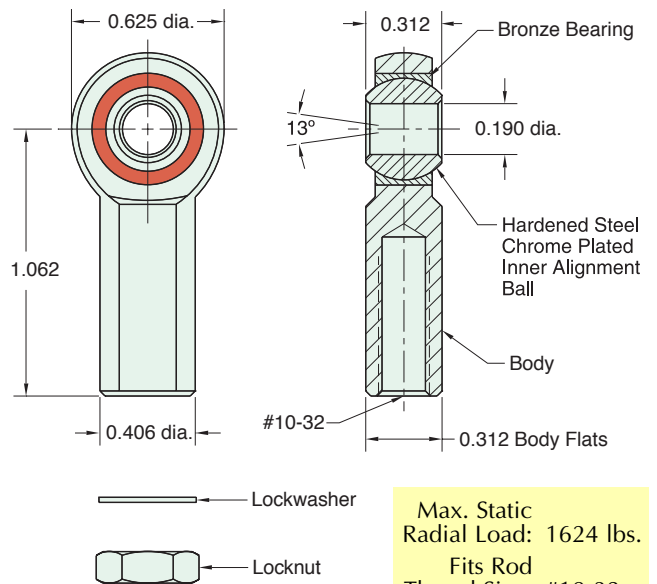

Max. Static Radial Load: 1624 lbs.
Fits Rod Thread Size: #10-32

FB-0892

Foot Bracket
Material: Steel, bright zinc plated

